

A			重要度	[B]			
B	<h3 style="margin: 0;">技术要求</h3> <ol style="list-style-type: none"> <li>1. 颜色要求：封面：彩色印刷 内页：彩色印刷； 批量时要求统一，不能有明显色差，</li> <li>2. 版面内容：图案与文字应印刷清晰、规范，不能有印刷缺陷；</li> <li>3. 页面印刷：双面印刷；</li> <li>4. 成型方式：骑马钉；</li> <li>5. 成品尺寸：A5 (140X210)， 尺寸公差按GB/T 1804-c；</li> <li>6. 批量生产前须送样确认。</li> </ol>						
C							
D							
借(通)用件登记							
出图审查	标志	处数	更改文件号	签名			
日期	设计	制图	审核	工艺			
1	2	3	4				
					封面：105g双铜 内页：105g双铜	广东奥马冰箱有限公司	
					重量	比例	说明书
					共 1 张	第 1 张	CKICK-AS'
					视角符号		

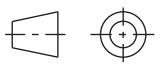

**Installation and Operating Manual**  
**Chest Freezer Model CF371W.E**



**Please read these instructions carefully before attempting to install or use this appliance.**

**It is advisable to keep these instructions in a safe place for future reference.**

Iceking: Henry John House Northway Industrial Estate Northway Lane Ashchurch  
Tewkesbury Gloucestershire GL20 8JH T: 01527 888133 E: [enquiries@ice-king.co.uk](mailto:enquiries@ice-king.co.uk)

W: [www.ice-king.co.uk](http://www.ice-king.co.uk)

## **INTRODUCTION:**

Thank you for choosing this **ICEKING** appliance. It has been designed to give years of trouble-free use provided it is installed and maintained correctly.

Please read these instructions carefully before installing or using your appliance. It is advisable to keep your purchase and installation receipts with these instructions in a safe place for future reference.

Included is some important safety information in addition to guidelines and recommendations that will enable you to take full advantage of all the functions available.

This quality appliance has been tested and certified to meet all applicable UK electrical and safety standards.

This appliance must be installed and connected in accordance with current regulations by a qualified electrician.

After unpacking the appliance ensure that there is no visible damage. If the appliance has been damaged during transit, do not use it, contact your retailer immediately.

### **Iceking Registered Office Address:**

**Henry John House,  
Northway Industrial Estate,  
Northway Lane, Ashchurch, Tewkesbury,  
Gloucestershire, GL20 8JH**

# User Manual

Chest Freezer

CF371W.E

Content	
1. Safety Information	Page 1~8
2. Overview	Page 9
3. Installation	Page 10~11
4. Daily Use	Page 12~17
5. Guarantee	Page 18~21

## Safety information

---

In the interest of your safety and to ensure the correct use, before installing and first using the appliance, read this user manual carefully, including its hints and warnings. To avoid unnecessary mistakes and accidents, it is important to ensure that all people using the appliance are thoroughly familiar with its operation and safety features. Save these instructions and make sure that they remain with the appliance if it is moved or sold, so that everyone using it through its life will be properly informed on appliance use and safety.

For the safety of life and property keep the precautions of these user's instructions as the manufacturer is not responsible for damages caused by omission.

### **Children and vulnerable people safety**





- This appliance can be used by children aged from 8 years and above and persons with reduced physical, sensory or mental capabilities or lack of experience and knowledge if they have been given supervision or instruction concerning use of the appliance in a safe way and understand the hazards involved.
- Children aged from 3 to 8 years are allowed to load and unload this appliance.
- Children should be supervised to ensure that they do not play with the appliance.
- Cleaning and user maintenance shall not be made by children unless they are aged from 8 years and above and supervised.
- Keep all packaging well away from children. There is risk of suffocation.

## Safety information

---

- If you are discarding the appliance pull the plug out of the socket, cut the connection cable (as close to the appliance as you can) and remove the door to prevent playing children to suffer electric shock or to close themselves into it.
- If this appliance featuring magnetic door seals it is to replace an older appliance having a spring lock(latch), make sure the spring lock is made unusable before your discard the old appliance. This will prevent it from becoming dangerous for children.

### General safety

-  **WARNING!** Keep ventilation openings, in the appliance enclosure or in the built-in structure, clear of obstruction.
-  **WARNING!** Do not use mechanical devices or other means to accelerate the defrosting process, other than those recommended by the manufacturer.
-  **WARNING!** Do not damage the refrigerant circuit.
-  **WARNING!** Do not use other electrical appliances (such as ice cream makers) inside of refrigerating appliance, unless they are approved for this purpose by the manufacture.
-  **WARNING!** Do not touch the light bulb if it has been on for a long period of time because it could be very hot.<sup>1)</sup>

1) If there is a light in the compartment

## Safety information

---

 **WARNING!** When positioning the appliance, ensure the supply cord is not trapped or damaged.

 **WARNING!** Do not locate the multiple portable socket-outlets or portable power suppliers at the rear of the appliance.

- Do not store explosive substances such as aerosol cans with a flammable propellant in this appliance.
- The refrigerant isobutane (R-600a) is contained within the refrigerant circuit of the appliance, a natural gas with a high level of environmental compatibility, which is nevertheless flammable.
- During transportation and installation of the appliance, be certain that none of the components of the refrigerant circuit become damaged.
  - avoid open flames and sources of ignition
  - thoroughly ventilate the room in which the appliance is situated
- It is dangerous to alter the specifications or modify this product in any way. Any damage to the cord may cause a short circuit, fire and/or electric shock. This appliance is intended to be used in household and similar applications such as
  - staff kitchen areas in shops, offices and other working environments;
  - farm houses and by clients in hotels, motels and other residential type environments;
  - bed and breakfast type environments;
  - catering and similar non-retail applications.

## Safety information

---

 **WARNING!** Any electrical components (plug, power cord, compressor and etc.) must be replaced by a certified service agent or qualified service personnel.

 **WARNING!** The light bulb supplied with this appliance is a “special use lamp bulb” usable only with the appliance supplied. This “special use lamp” is not usable for domestic lighting.<sup>1)</sup>

- Power cord must not be lengthened.
- Make sure that the power plug is not squashed or damaged by the back of the appliance. A squashed or damaged power plug may overheat and cause a fire.
- Make sure that you can come to the mains plug of the appliance.
- Do not pull the mains cable.
- If the power plug socket is loose, do not insert the power plug. There is a risk of electric shock or fire.
- You must not operate the appliance without the lamp.
- This appliance is heavy. Care should be taken when moving it.
- Do not remove or touch items from the freezer compartment if your hands are damp/wet, as this could cause skin abrasions or frost/freezer burns.
- Avoid prolonged exposure of the appliance to direct sunlight.



## Safety information

---

### Daily use

- Do not put hot on the plastic parts in the appliance.
- Do not place food products directly against the rear wall.
- Frozen food must not be re-frozen once it has been thawed out.<sup>1)</sup>
- Store pre-packed frozen food in accordance with the frozen food manufacturer's instructions.<sup>1)</sup>
- Appliance's manufacturer's storage recommendations should be strictly adhered to. Refer to relevant instructions.
- Do not place carbonated or fizzy drinks in the freezer compartment as it creates pressure on the container, which may cause it to explode, resulting in damage to the appliance.<sup>1)</sup>
- Ice lollies can cause frost burns if consumed straight from the appliance.<sup>1)</sup>
- If the appliance is left empty for long periods, switch off, defrost, clean, dry and leave the door open to prevent mould developing within the appliance.

### Care and cleaning

- Before maintenance, switch off the appliance and disconnect the mains plug from the mains socket.
- Do not clean the appliance with metal objects.
- Do not use sharp objects to remove frost from the appliance. Use a plastic scraper.<sup>1)</sup>
- Regularly examine the drain in the refrigerator for defrosted water. If necessary, clean the drain. If the drain is blocked, water will collect in the bottom of the appliance.<sup>2)</sup>

1) If there is a freezer compartment

2) If there is a fresh-food storage compartment

## Safety information

---

### Installation

**Important!** For electrical connection carefully follow the instructions given in specific paragraphs.

- Unpack the appliance and check if there are damages on it. Do not connect the appliance if it is damaged. Report possible damages immediately to the place you bought it. In that case retain packing.
- It is advisable to wait at least four hours before connecting the appliance to allow the oil to flow back in the compressor.
- Adequate air circulation should be around the appliance, lacking this leads to overheating. To achieve sufficient ventilation, follow the instructions relevant to installation.
- Wherever possible the spacers of the product should be against a wall to avoid touching or catching warm parts (compressor, con-denser) to prevent possible burn.
- The appliance must not be located close to radiators or cookers.
- Make sure that the mains plug is accessible after the installation of the appliance

### Service

- Any electrical work required to do the servicing of the appliance should be carried out by a qualified electrician or competent person.
- This product must be serviced by an authorized Service Center, and only genuine spare parts must be used.



## Safety information

---

### Energy Saving

- Don't put hot food in the appliance;
- Don't pack food close together as this prevents air circulating;
- Make sure food don't touch the back of the compartment(s);
- If electricity goes off, don't open the door(s);
- Don't open the door(s) frequently;
- Don't keep the door(s) open for too long time;
- Don't set the thermostat on exceeding cold temperatures;
- All accessories, such as drawers, shelves & balconies, should be kept there for lower energy consumption.

### Environment Protection

 This appliance does not contain gases which could damage the ozone layer, in either its refrigerant circuit or insulation materials. The appliance shall not be discarded together with the urban refuse and rubbish. The insulation foam contains flammable gases: the appliance shall be disposed of according to the appliance regulations to obtain from your local authorities. Avoid damaging the cooling unit, especially the heat exchanger. The materials used on this appliance marked by the symbol  are recyclable.



The symbol on the product or on its packaging indicates that this product may not be treated as household waste. Instead, it should be taken to the appropriate collection point for the recycling of

## Safety information

---

electrical and electronic equipment. By ensuring this product is disposed of correctly, you will help prevent potential negative consequences for the environment and human health, which could otherwise be caused by inappropriate waste handling of this product. For more detailed information about recycling of this product, please contact your local council, your household waste disposal service or the shop where you purchased the product.

### **Packaging materials**

The materials with the symbol are recyclable.

Dispose the packaging in a suitable collection container to recycle it.

### **Disposal of the appliance**

1. Disconnect the mains plug from the mains socket.
2. Cut off the mains cable and discard it.



**WARNING!** During using, service and disposal of the appliance, please pay attention to symbol similar as left side, which is located on rear of appliance (rear panel or compressor) and with yellow or orange color.

It's a risk of fire warning symbol. There are flammable materials in refrigerant pipes and compressor.

Please be far away from fire a source during using, service and disposal.

## Overview

---

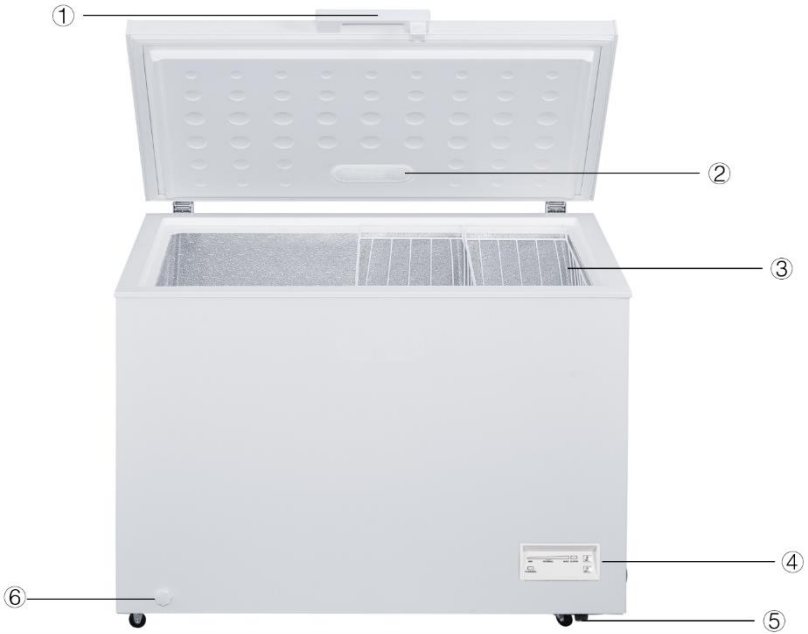

1. External Handle
2. LED Light
3. Wire Basket
4. User Interface
5. Wheel
6. Drain Hole

Note: This installation is only for hinting. For details, please check your appliance.

# Installation

---

## Install External Handle on Door

### Step1

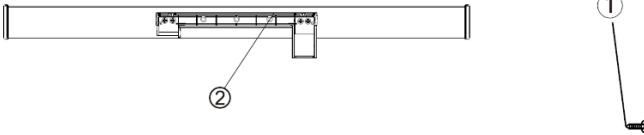

### Step 1

Take out 4 screws ① and handle base ② from accessory bag.

Then fix the handle base ② with door by 4 screws ① .

### Step2

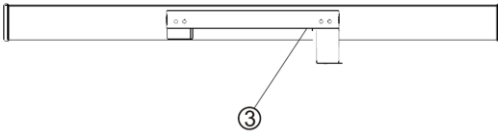

### Step 2

Insert the handle cover ③ in the handle base ② until you hear a click sound.

# Installation

## Space Requirement

- The following space is recommended.
- Clearances around the chest freezer  
Sides ----- 10cm  
Back ----- 10cm  
Top ----- 70cm

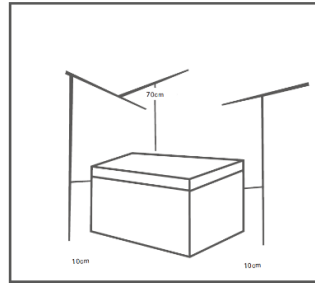

## Positioning

Install this appliance at a location where the ambient temperature corresponds to the climate class indicated on the rating plate of appliance:

Climate class	Ambient temperature
SN	+10°C to +32°C
N	+16°C to +32°C
ST	+16°C to +38°C
T	+16°C to +43°C

## Location

The appliance should be installed well away from sources of heat such as radiators, boilers, direct sunlight etc. Ensure that air can circulate freely around the back of the cabinet. To ensure best performance, if the appliance is positioned below an overhanging wall unit, the minimum distance between the top of the cabinet and the wall unit must be at least 100mm. Ideally, however, the appliance should not be positioned below overhanging wall units. Accurate leveling is ensured by one or more adjustable feet at the base of the cabinet.



**Warning!** It must be possible to disconnect the appliance from the mains power supply; the plug must therefore be easily accessible after installation

## Electrical connection

Before plugging in, ensure that the voltage and frequency shown on the rating plate correspond to your domestic power supply. The appliance must be earthed. The power supply cable plug is provided with a contact for this purpose. If the domestic power supply socket is not earthed, connect the appliance to a separate earth in compliance with current regulations, consulting a qualified electrician.

The manufacturer declines all responsibility if the above safety precautions are not observed. This appliance complies with the E.E.C. Directives.

## Daily Use

---

### First Use

#### Cleaning the interior

Before using the appliance for the first time, wash the interior and all internal accessories with lukewarm water and some neutral soap so as to remove the typical smell of a brand new product, then dry thoroughly.

**Important!** Do not use detergents or abrasive powders, as these will damage the finish.

### Control Panel

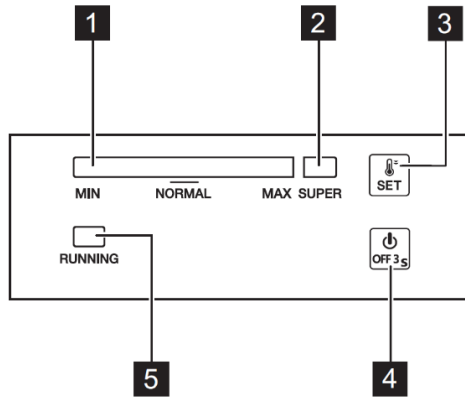

- 1** Temperature indicator
- 2** SUPER indicator
- 3** SET button
- 4** OFF button
- 5** Running indicator

### Switching ON/OFF

1. To switch on the appliance insert the plug into the mains socket.
2. If the indicators are off, press the OFF button for 3 seconds.
3. To switch off the appliance, press the OFF button for 3 seconds.



## Daily Use

---

### Temperature regulation

To set the temperature:

1. Press SET button repeatedly until you reach the desired temperature. MAX setting is the coldest one.
2. The temperature sets 5 seconds after the last press. The exact setting should be chosen keeping in mind that the temperature inside the appliance depends on:
  - room temperature
  - how often the lid is opened
  - the quantity of food stored
  - the location of the appliance.

### SUPER function

The SUPER function accelerates the freezing of fresh food and, at the same time, protects already stored foodstuffs from undesired warming.

To activate the function:

1. Press SET button repeatedly until the SUPER indicator lights up.
2. The function sets 5 seconds after the last press. The SUPER function stops automatically after 52 hours and the temperature goes back to the previous setting. You can stop the function manually before that time, by pressing the SET button and setting the desired temperature.

### RUNNING indicator

This indicator is on when the compressor operates and it turns off when the compressor stops working.

### Resumption function

This appliance will automatically resume the mode previously set before the electrical outage.

### Temperature sensor fault alarm

When there is a disconnection or short out of the temperature sensor, as a fault alarm, the temperature indicator will flash from left to right every 0.5 seconds.

### Freezing fresh food

This appliance is suitable for freezing fresh food and storing frozen and deep-frozen food for a long time. The maximum amount of food that can be frozen in 24 hours is specified on the rating plate (refer to "Technical data").

**Important!** Start the SUPER function 24 hours before placing food in the appliance. The freezing process lasts 24 hours, during this period do not add other food to be frozen.

## Daily Use

---

### Storing frozen food

When first starting-up or after a period out of use, before putting the products in the compartment let the appliance run at least 24 hours on the higher settings.

**CAUTION!** In the event of accidental defrosting, for example due to a power failure, if the power has been off for longer than the value shown in the technical characteristics chart under "rising time", the defrosted food must be consumed quickly or cooked immediately and then re-frozen (after cooling).

### Thawing

Deep-frozen or frozen food, prior to being used, can be thawed in the refrigerator or at room temperature, depending on the time available for this operation.

Small pieces may even be cooked still frozen, directly from the freezer: in this case, cooking will take longer.

## Helpful hints and tips

### Hints for freezing

To help you make the most of the freezing process, here are some important hints:

- the maximum quantity of food which can be frozen in 24 hrs. is shown on the rating plate;
- the freezing process takes 24 hours. No further food to be frozen should be added during this period;
- only freeze top quality, fresh and thoroughly cleaned, foodstuffs;
- prepare food in small portions to enable it to be rapidly and completely frozen and to make it possible subsequently to thaw only the quantity required;
- wrap up the food in aluminum foil or polythene and make sure that the packages are airtight;
- do not allow fresh, unfrozen food to touch food which is already frozen, thus avoiding a rise in temperature of the latter;
- lean foods store better and longer than fatty ones; salt reduces the storage life of food;
- water ices, if consumed immediately after removal from the freezer compartment, can possibly cause the skin to be freeze burnt;
- it is advisable to show the freezing in date on each individual pack to enable you to keep tab of the storage time.

### Hints for storage of frozen food

To obtain the best performance from this appliance, you should:

- make sure that the commercially frozen foodstuffs were adequately stored by the retailer;
- be sure that frozen foodstuffs are transferred from the food store to the freezer in the shortest possible time;
- do not open the door frequently or leave it open longer than absolutely necessary;
- once defrosted, food deteriorates rapidly and cannot be re-frozen;
- do not exceed the storage period indicated by the food manufacture.

## Daily Use

---

### Cleaning

For hygienic reasons the appliance interior, including interior accessories, should be cleaned regularly.



**Caution!** The appliance may not be connected to the mains during cleaning. Danger of electrical shock! Before cleaning, switch the appliance off and remove the plug from the mains, or switch off or turn out the circuit breaker or fuse. Never clean the appliance with a steam cleaner. Moisture could accumulate in electrical components, danger of electrical shock! Hot vapors can lead to the damage of plastic parts. The appliance must be dry before it is placed back into service.

**Important!** Etheral oils and organic solvents can attack plastic parts, e.g. lemon juice or the juice for orange peel, butyric acid, cleanser that contain acetic acid.

- Do not allow such substances to come into contact with the appliance parts;
- Do not use any abrasive cleaners;
- Remove the food from the freezer. Store them in a cool place, well covered;
- Switch the appliance off and remove the plug from the mains, or switch off to turn out the circuit breaker or fuse;
- Clean the appliance and the interior accessories with a cloth and lukewarm water. After cleaning wipe with fresh water and rub dry.
- After everything is dry place appliance back into service.

### Defrosting the freezer



**CAUTION!** Never use sharp metal tools to scrape off frost as you could damage the appliance.

Do not use a mechanical device or any artificial means to speed up the

Defrost the freezer when the frost layer reaches a thickness of about 10-15 mm.

1. Switch off the appliance.
2. Remove any stored food, wrap it in several layers of newspaper and put it in a cool place.
3. Remove the drain plug from the inside of the appliance.
4. Leave the lid open.
5. Place a tray beneath the outer drain plug.
6. Pull out the outer drain plug.

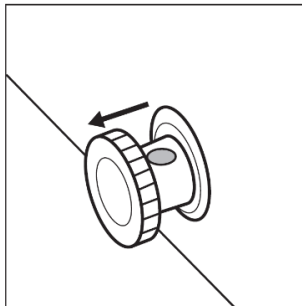

## Daily Use

---

7. Rotate the drain plug 180 degrees to let the drain water flow into the tray.

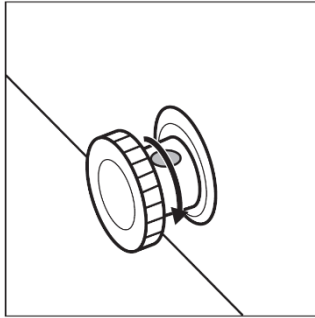

Make sure the water does not spill out of the tray.

8. Clean the interior and dry it thoroughly.
9. Switch on the appliance.
10. Set the temperature to MAX setting and close the lid. Wait two or three hours before you reload previously removed food into the appliance.
11. Set the temperature to the desired setting.

# Daily Use

## Troubleshooting

 **Caution!** Before shooting any trouble, disconnect the power supply. Only a qualified electrician of competent person must do the trouble shooting that is not in this manual. Important! There are some sounds during normal use (compressor, refrigerant circulation).

Problem	Possible Cause	Solution
Appliance does not work	Mains plug is not plugged in or is loose	Insert mains plug
	Fuse has blown or is defective	Check fuse, replace if necessary
	Socket is defective	Mains malfunctions are to be corrected by an electrician
Appliance freezes too much	Temperature is set too cold or the appliance runs at <b>SUPER</b> setting	Turn the temperature regulator to a warmer setting temporarily
The food is not frozen enough	Temperature is not properly adjusted	Please look in the initial Temperature Setting section
	Door was open for an extended period	Open the door only as long as necessary
	A large quantity of warm food was placed in the appliance within the last 24 hours	Turn the temperature regulator to a colder setting temporarily
	The appliance is near a heat source	Please look in the installation location section
Heavy build-up of frost on the door seal	Door seal is not air-tight	Carefully warm the leaking sections of the door seal with a hair dryer (on a cool setting). At the same time shape the warmed door seal by hand such that it sits correctly
Unusual noises	Appliance is not level	Check the appliance and level it with some articles.
	The appliance is touching the wall or other objects	Move the appliance slightly
	A component, e.g. a pipe, on the rear of the appliance is touching another part of the appliance or the wall	If necessary, carefully bend the component out of the way

If the malfunction shows again, contact the Service Center. These data are necessary to help you quickly and correctly. Write the necessary data here, refer to the rating plate.

## Guarantee

### **YOUR 2 YEAR MANUFACTURER'S GUARANTEE**

#### **THIS DOES NOT AFFECT YOUR STATUTORY RIGHTS**

Your new ICEKING appliance carries a free guarantee which protects you against the cost of repairs during the first 24 months from date of purchase provided that any claim is accompanied by evidence of the model reference, model serial number and proof of purchase, such as a Sales Receipt, showing that the appliance was purchased within the 24 months prior to the date of claim.

#### **YOUR GUARANTEE IS VALID ONLY IN THE UK & REPUBLIC OF IRELAND**

To register your appliance, simply complete the card in your appliance pack and return it with a stamp affixed or *alternatively* you can register online at [www.registernowonline.co.uk](http://www.registernowonline.co.uk)

#### **Service Helpline**

Should your appliance develop a fault, please call the Iceking Service Helpline on:

**01527 888133**

Please remember to have all your product details available, including the model number, serial number, date of purchase and your retailer's details before registering a fault.

Your service call cannot progress without this information.

#### **WHAT IS NOT COVERED UNDER THE GUARANTEE:**

- Any appliance not correctly installed and operated in accordance with the manufacturer's instructions
- Any appliance that is used for anything other than domestic purposes.
- Any defect caused by accident, misuse, unauthorised modification or inexpert repair.

## Guarantee

- Cost of callout where a fault cannot be found with the appliance.
- Cost of callout for work covering routine maintenance, such as, but not exclusively, cleaning of filters or defrosting.
- Cost of callout for work required to correct the alignment of doors following door reversal procedures carried out by you.
- Use of the appliance by anyone other than the Householder.
- Use in a non-domestic environment.
- Consumable items, such as, but not exclusively, fuses in plugs, bulbs and breakable items which require routine replacement.
- Repair costs incurred that have not been authorised by the Repairtech and/or carried out by a non-approved Repairtech engineer.

## Insurance

**!! Any warranty provided with this product does not cover loss of fridge/freezer content !!**

Any claim for loss, damage, costs or expenses of an indirect or consequential nature including any economic loss or damage to foodstuffs or any other goods is excluded. We recommend that you inspect your fridge/freezer regularly to check that it is working correctly, losses can result from deterioration following breakdown or accidental failure of the appliance, fuses, plugs or public electricity supply, these can be covered by your standard home insurance or might require extra cover. Check with your insurance provider.

## Special for new European standard

The ordered parts in the following table can be acquired from customer services.

Ordered Parted	Provided By	Minimum Time Required For provision.
Thermostats	Professional maintenance personnel	At least 7 years after the last model is launched on the market
Temperature Sensor	Professional maintenance personnel	At least 7 years after the last model is launched on the market
Printed Circuit board	Professional maintenance personnel	At least 7 years after the last model is launched on the market
Light Source	Professional repairers and final users	At least 7 years after the last model is launched on the market
Door Handles	Professional repairers and final users	At least 7 years after the last model is launched on the market
Door Hinges	Professional repairers and final users	At least 7 years after the last model is launched on the market
Trays	Professional repairers and final users	At least 7 years after the last model is launched on the market
Baskets	Professional repairers and final users	At least 7 years after the last model is launched on the market
Door gaskets	Professional repairers and final users	At least 10 years after the last model is launched on the market

### Product Data Sheet concerning (EU) 2019/2019

The product data sheet for your appliance can be found online if you wish to download a copy.

Go to <https://eprel.ec.europa.eu> and enter the model identifier for your appliance to download the data sheet.

Alternatively you can download from [www.ice-king.co.uk](http://www.ice-king.co.uk) by going to the relevant product page.

The model identifier for your appliance can be found on the rating plate at the rear/ inside of the appliance.



## Important Note:

This appliance is marked according to the European directive 2002/96/EC on Waste Electrical and Electronic Equipment (WEEE). By ensuring this product is disposed of correctly, you will help prevent potential negative consequences for the environment and human health, which could otherwise be caused by inappropriate waste handling of this product.

The symbol on the product, or on the documents accompanying the product, the Crossed Out Wheelie Bin, indicates that this appliance may not be treated as household waste. Instead it shall be handed over to the applicable collection point for the recycling of electrical and electronic equipment.

Disposal must be carried out in accordance with local environmental regulations for waste disposal. For more detailed information about treatment, recovery and recycling of this product, please contact your local authority, your household waste disposal service or the retailer where you purchased the product.



---

We continuously try to improve our products for the benefit of our customers. For this reason we reserve the right to make changes to any product at any time, without notice

Issue: 01/25.05.2023